

2-Band FM Scanning Monitor Receiver

VHF Lo : 30 - 50 MHz VHF Hi : 148 - 174 MHz



PRO-45

**OWNER'S
MANUAL**

REALISTIC®

CUSTOM MANUFACTURED FOR RADIO SHACK  A DIVISION OF TANDY CORPORATION

Your PATROLMAN PRO-45 scanning receiver is a completely transistorized VHF HI/LO superheterodyne receiver using dual-conversion.

It is capable of automatically scanning eight crystal-controlled channels. Some special features are: lock-out circuit, skipper circuit, scan delay circuit, "Track-Tuning" front-end (using a Vari-cap tuning system on both bands), and AC or DC operation.

It is designed for use in the narrow-band FM channels of public service communications: VHF-Hi/Lo band police, fire, civil defense, radio telephone, forestry and weather service, plus many other industrial radio services and the 2-meter Ham radio band (upper end). These and many other services share this band of frequencies from 30 to 50 MHz and 148 to 174 MHz.

The PRO-45 features both high sensitivity and selectivity and a sophisticated circuit which includes a 10.7 MHz crystal filter and a 455 kHz ceramic filter to reduce or eliminate adjacent-channel or strong-signal interference. Such interference is often experienced when operating in urban and metropolitan areas or where very strong and closely placed signals are present.

An important engineering achievement, designed for practical applications, the PRO-45 is remarkably easy to use, yet its up-to-date, complex circuit consists of 15 separate transistors (two of which are Field Effect Transistors), five integrated circuits (which incorporate the equivalent of hundreds of components) and 26 diodes.

This Receiver is designed to operate from either 120 volts AC or 12 volts DC **Negative Ground**. If it fails to operate, and there is no clear reason for the failure, first check the "power" switch (part of **Volume** control). Also, before connecting the PRO-45 receiver to a DC power supply, check the voltage polarity. Attempting to operate the negative-ground PRO-45 from one of the rare positive-ground automotive or boat electrical systems, or from a wrongly connected battery, will at least blow a fuse. It may do further damage, so that expensive and time-consuming repairs are necessary before the PRO-45 can be used again. The Radio Shack warranty does not apply to any damage caused by this, inadequate lightning protection, or other improper connections.

For your own protection, we urge you to record the Serial Number of this unit in the space provided. You'll find the Serial Number on the back panel of the unit.

Serial Number

SPECIFICATIONS

SEMICONDUCTORS:	15 transistors, 5 integrated circuits and 26 diodes
FREQUENCY RANGE:	30 ~ 50 MHz and 148 ~ 174 MHz
CHANNELS OF OPERATION:	Eight - as determined by any one of 8 crystals operating in the frequency range
FREQUENCY COVERAGE:	VHF Low 30 ~ 50 MHz VHF High 148 ~ 174 MHz
SENSITIVITY: (S+N)/N = 20 dB	VHF Low Better than 0.8 μ V at 40 MHz VHF High Better than 0.5 μ V at 160 MHz
SELECTIVITY:	-6 dB \pm 9 kHz -50 dB \pm 17 kHz
SPURIOUS REJECTION:	Greater than 50 dB
SIGNAL TO NOISE RATIO:	50 dB
SCANNING RATE:	10 channels/second
SCAN DELAY TIME:	2 seconds
MODULATION ACCEPTANCE:	\pm 7 kHz
I.F. FREQUENCY:	10.7 MHz and 455 kHz
FILTER:	Crystal filter (10.7 MHz), Ceramic filter (455 kHz)
SQUELCH SENSITIVITY:	Variable from less than 0.5 micro-volt
AUDIO POWER:	2 watts maximum
CRYSTAL REQUIREMENTS:	Standard HC-25/U, 3rd overtone
BUILT-IN SPEAKER:	2" x 6" (5 x 15 cm) Oval speaker
POWER REQUIREMENTS:	AC-120 volts, 60 Hz, 16 watts maximum DC-12-15 volts Negative Ground only (10 watts maximum)

WARNING: TO PREVENT FIRE OR SHOCK HAZARD, DO NOT EXPOSE THIS RECEIVER TO RAIN OR MOISTURE.

PREPARING FOR USE

To use your PRO-45, you must do three things:

- Connect power
- Install from 1 to 8 crystals
- Connect an antenna

To make a quick check, you can just connect the Line Cord to a source of 120 volts, 60 Hz, AC power. If you intend to use a 12 volt source, you must connect the 12 volt DC power plug wires as noted later on under "Mobile Installation". With an antenna connected and a crystal installed, turn the Receiver on by rotating **VOLUME** clockwise. Rotate **SQUELCH** maximum counterclockwise. You should hear a "rushing" sound in the speaker.

Crystals are not included with your PRO-45 because the frequencies are so numerous. The frequencies used in your part of the country will be different from those used in other areas. Order the crystals you want from your Radio Shack store—specify the model number of this unit and the frequency you want to receive.

Remove the one Screw from the Crystal Compartment Cover (top of cabinet) to expose the crystal sockets and program switches. Provision is made for up to 8 crystals; each program switch can be set to obtain either VHF Lo or VHF Hi.

For VHF Hi, set the program switch to H (marked "H" on printed circuit board).

For VHF Lo, set the program switch to L (marked "L" on printed circuit board).

In the example shown channel 1 will have a VHF Hi crystal and channel 8 will have a VHF Lo crystal.

Ask the manager of your Radio Shack store what the most popular and active channels are in your area. He will be glad to advise you.

NOTE: In some states or areas it may not be permissible to use a monitor receiver in a vehicle. Just to be sure, you should check local regulations before using this unit.

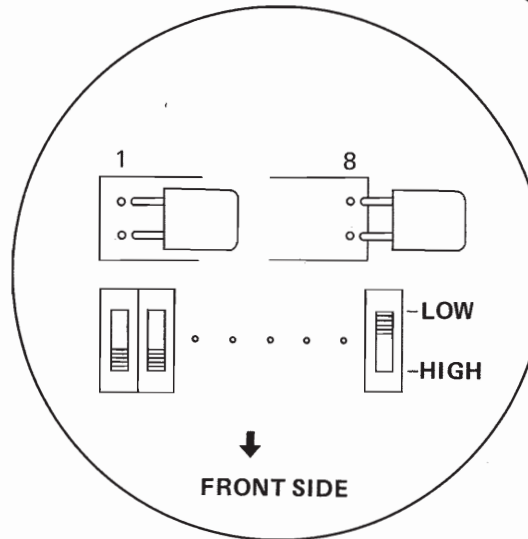
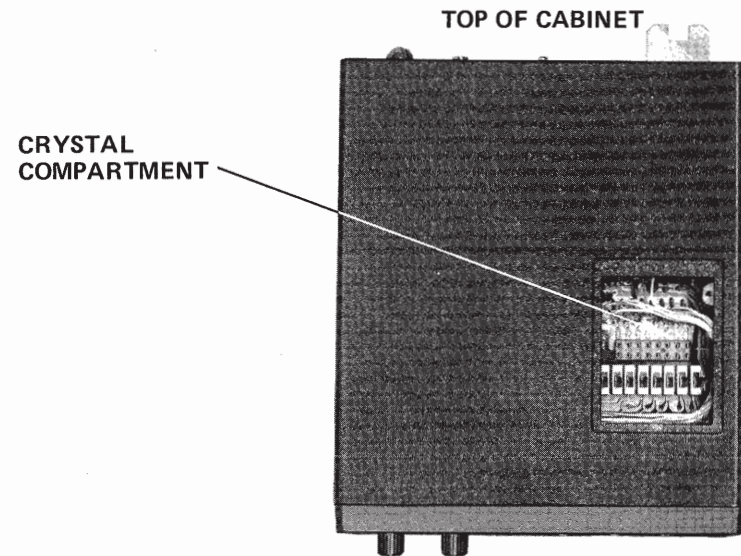

Since crystal frequencies must be extremely accurate and crystals should be matched for specific units, we recommend you obtain crystals for your Receiver **only** from Radio Shack. We cannot be responsible for the poor or improper operation of crystals from any other manufacturer(s).

CONTROL LOCATION AND FUNCTION

OFF-VOLUME is the power switch and Volume control. When not in use, rotate this control maximum counter-clockwise to turn it off.

SQUELCH control is to eliminate annoying background noise between signal transmissions. When properly set, **SQUELCH** will keep the PRO-45 silent until a signal comes in on the channel(s) you are listening to—then, the Squelch circuit will “open” and you hear the signal.

SCAN Button is for determining the function of the scanning feature. In the “in” position, each channel will be scanned automatically. In the “out” position, the PRO-45 will not scan, but will remain tuned to the channel indicated by a Lighted Channel Indicator.

MANUAL Selector Button—when the **SCAN** button is in the “out” position, use this button to advance the Receiver to the next channel in sequence. Each time you press this button, the Receiver will advance just one channel.

Channel Lock-Out Button/Channel LED Indicators—in the “in” position (button pressed in), that channel is active. When you press the button again (to pop it “out”), that channel is automatically “locked out” and will not function.

The LED indicators light up to show which channel is active. During scanning, they light up in sequence; when the Receiver is operative on one of the channels, the light for that channel will remain lit. When the Channel Lock-Out Button for that channel is “out”, that LED will not light.

ANTENNA Jack—for VHF Lo and VHF Hi reception—connect an antenna to this jack. Use an antenna such as Catalog Number 20-161 (indoor operation).

EXT. SPKR jack is for plugging in headphones or an external speaker. Use it for private listening, or in areas where background noise is excessive (in factories, at the scene of an accident or fire, in a vehicle, etc.). If you want a remote speaker, plug it in here. Connecting a plug to this jack automatically disconnects the internal speaker.

Mounting Bracket—this universal type bracket is provided for quick and easy installation in a vehicle or boat or for permanent installation as a base station.

Line Cord—for AC operation, plug into a source of 120 volts, 60 Hz AC power.

Crystal/Program Switch Compartment—remove screws to open the case top to install or replace crystals.

DC Power jack is for connecting an external source of 12-volts DC, negative ground. This will permit you to use the PRO-45 in a vehicle or boat.

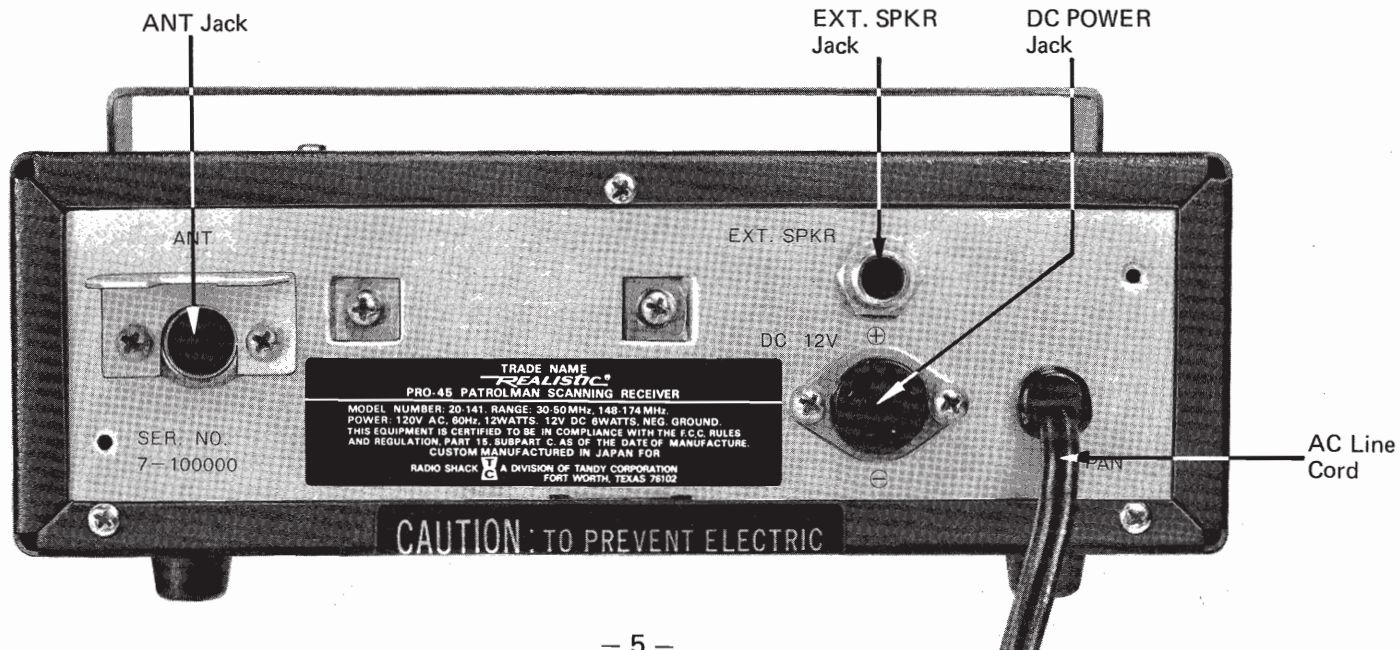
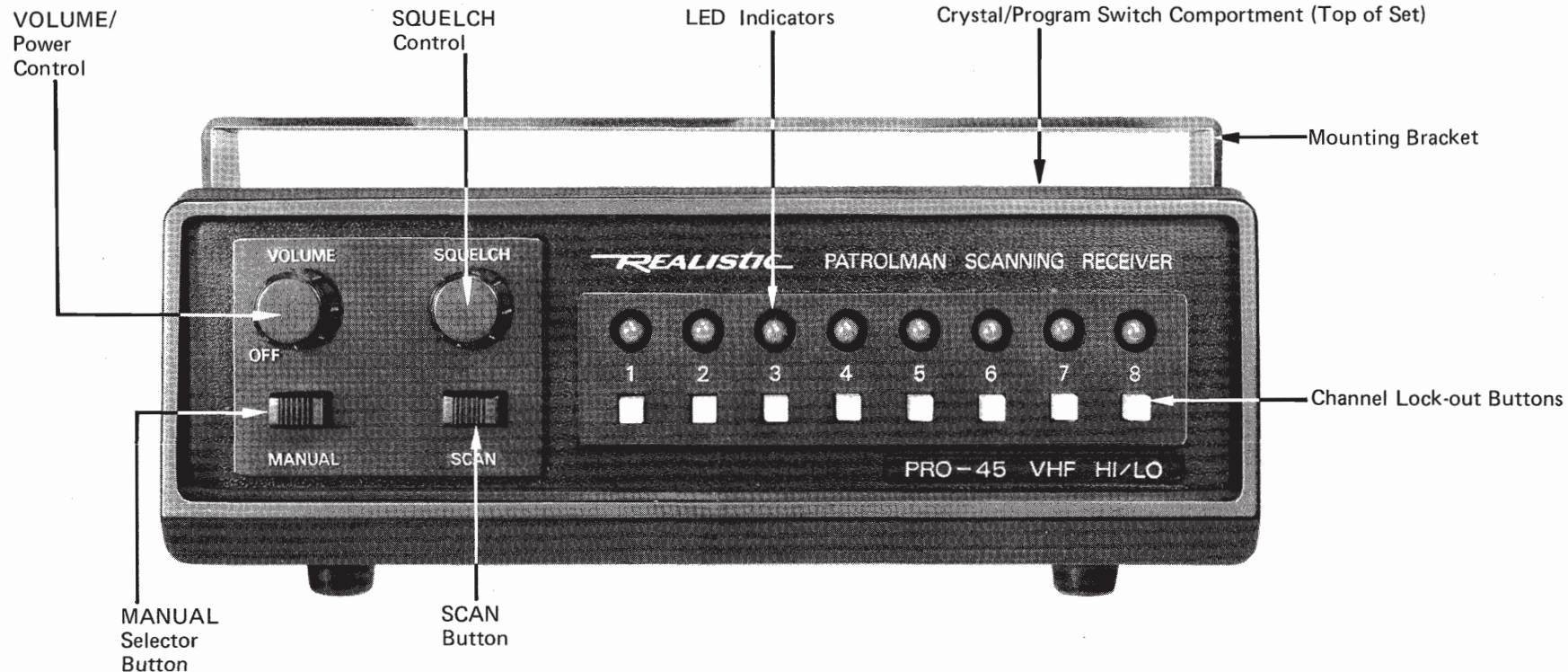

INSTALLATION

Once you've got the right crystal(s) for your area and your interests, you only need two things: a VHF-Hi/Lo antenna and a source of power, either 120 volts AC or 12 volts DC negative ground. Whether you plan to use your PRO-45 at home or in a mobile installation, the choice of a proper antenna is of utmost importance. A variety of suitable antennas is described below, and all are available at your local Radio Shack.

BASE INSTALLATION

The very simplest way to use your PRO-45 at home is with an indoor, plug-in antenna. The telescoping whip plugs directly into the back of the scanner. For some frequencies, an indoor antenna is perfectly adequate. However, for top reception of all frequencies you may be interested in, you'll want an external, base-station antenna. Use RG 58/U coaxial lead-in cable for maximum transfer of the tiny radio signals.

The only other thing you need to do is to connect the line cord to a source of 120 volts, 60 Hz, AC power.

Base Antennas



20-015

Since your Receiver tunes in both high and low VHF we suggest an antenna such as our Hi-Low VHF Ground Plane 20-015.

If you're only interested in frequencies on the VHF-Hi (148 ~ 174 MHz) band, you might want our VHF-Hi Ground Plane, 20-176.

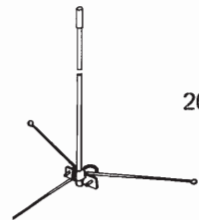

20-176

20-161

A convenient indoor antenna is our VHF-Hi/Lo Plug-In, 20-161.

MOBILE INSTALLATION

Safety and operating convenience are the primary factors to consider when you install any equipment in a vehicle. Be sure you can easily reach the Receiver's controls. Also, be sure the connecting cables do not interfere with the operation of the vehicle (brake, accelerator, etc.).

You can mount the Receiver on the underside of the dash or instrument panel in the vehicle or boat. Use the universal mounting bracket provided. Take care when drilling holes that you do not drill into existing wires or trim.

The PRO-45 is designed for mobile use with a negative ground 12 volt DC source. Be sure you connect power leads with the correct polarity. Use the DC power cable provided. The other end of these wires can be connected to an Auto Cigarette Lighter Plug, Catalog Number 274-331, or you can make the connections directly to the fuse block of the vehicle or boat. Be sure to observe correct voltage polarity: red to + and black to -.

IMPORTANT: If your car has been burning out headlamps and other bulbs at a rapid rate, first have the voltage regulator checked for proper output: excessive voltage (more than 16 volts) can cause serious damage to your receiver.

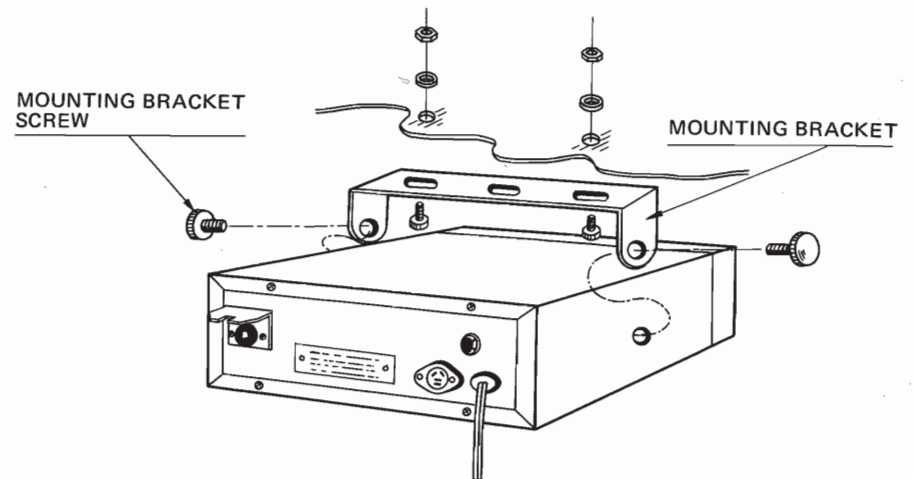

Mobile Antennas

There are many possible mounting locations on a car. Three of the most popular locations for monitor antennas are shown below.

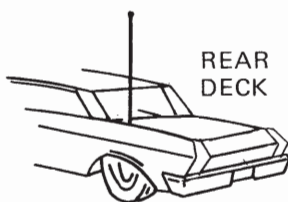
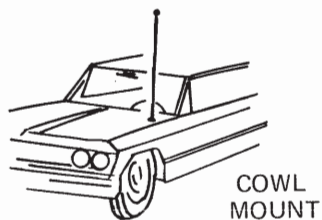
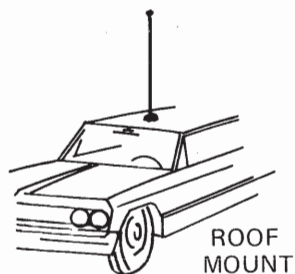

A convenient and efficient antenna for mobile use is Radio Shack's VHF-Hi/Lo UHF-Hi/Lo No-Hole Trunk Mount Mobile, 20-017.

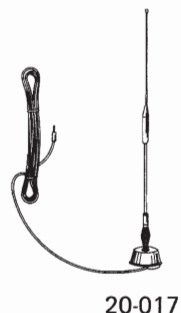

Keep the following points in mind when installing your mobile antenna.

1. Mount it rigidly, so it will remain vertical while in motion.
2. Mount as far as possible from the engine compartment.

MOBILE NOISE SUPPRESSION

Your PRO-45 is a very sensitive receiver, and will pick up signals that are extremely weak. This means that in addition to the tiny radio signals, radio frequency noise may also be picked up and amplified. In a mobile installation, it is important that you take steps to reduce the amount of noise that finds its way into the receiver. If you take some or all of the steps recommended below (as indicated by your Radio's performance), your reception will be quite satisfactory for mobile applications.

Electrical System:

Generally speaking, noise can be generated by any device or connection that carries electrical current. Any device that generates a spark should also be suspected. Bypass any suspected wire to ground with a high quality $1\mu\text{F}$ coaxial capacitor.

A very common source of noise is the generator or alternator. This type of noise will sound like a musical whine, and will also vary with speed of the engine. Generator and alternator noise can usually be reduced by connecting a coaxial-type capacitor from the armature terminal to the metal case.

Ignition System:

The ignition system is the most common source of noise. This noise can be identified by the fact that its speed varies with the engine speed. Ignition noise will sound like a series of "popping" sounds, while the engine is idling, and will speed up to a buzzing sound as engine speed is increased.

There are a number of things that can be done for this type of noise.

1. Use radio suppression-type ignition wire and resistor spark plugs.
2. Check high-voltage wiring for leakage, cracks, etc. Replace any old wiring.
3. In extreme cases, obtain an ignition noise suppression kit—it should shield all ignition wiring. This will provide maximum noise suppression.

OPERATION

After power and antennas are connected and a crystal (or crystals) has been installed, your PRO-45 is ready to use.

Turn **VOLUME** "on", by rotating clockwise. Rotate **SQUELCH** fully counterclockwise. Set all the Channel Lock-Out Buttons "on" (press in). You should hear a rushing sound from the speaker. Now adjust **SQUELCH** clockwise until you no longer hear the rushing background noise (further explanation of **SQUELCH** adjustment is noted below).

If you want the PRO-45 to continuously scan the channels for which you have crystals installed, you must adjust **SQUELCH** as instructed above, then press SCAN button in, to the AUTO position. The PRO-45 will constantly scan each channel in sequence; when a signal appears on one of the channels, the receiver will lock onto that channel and you will hear the signal.

If you do not want automatic scanning on one or more channels, press their Channel Lock-out Buttons "off" (press in to release the button so it pops out).

If you want to stay tuned to one channel only, press SCAN button again to make it pop out to the Scan-Off position. The Receiver will stop automatic scanning; now press **MANUAL** Selector button to advance to the channel you want to listen to (as indicated by a lighted LED). For scanning, the receiver can be either "squelched" or "unsquelched"; for automatic scanning, **SQUELCH** must be set to eliminate the background noise.

To eliminate the annoying background noise, rotate **SQUELCH** clockwise until the background noise just stops. You can't adjust **SQUELCH** properly while listening to a station, so wait till signals cease. If you set **SQUELCH** as noted above, the PRO-45 will appear "dead" until a signal comes in; when a signal comes in, the Squelch circuit "opens up" and you hear the signal. When the signal ceases, the Squelch circuit "closes" and cuts out all sound until the next signal comes in.

SCAN DELAY:

The PRO-45 has a built-in two second delay feature which virtually eliminates missed replies. This circuit holds the Receiver on the channel you are monitoring for a period of two seconds after the carrier has gone off the air, before it resumes normal scanning.

SKIPPER CIRCUIT:

Your scanner has a built-in skipper circuit which is fully automatic and can not be disabled. It works in both the Auto and Manual modes of operation. This feature causes the unit to skip over any locked out channel(s) so that there is no possibility of the Receiver's stopping on the locked out channel(s).

ACCESSORIES

A pair of headphones can be a very useful accessory. In areas where a high noise level is present (in a factory, at the scene of a fire or accident, etc.), or when you want to listen privately, use headphones. Your Radio Shack store has a couple of very fine selections for your PRO-45. Just plug them into the rear panel EXT. SPKR jack.

If you want to listen to the Receiver from a remote position, or just want to use an external speaker, connect it to the EXT. SPKR jack. We recommend Radio Shack's 40-1244, a weatherized, rugged 4" (10cm) Speaker — it is uniquely suited for this type of application.

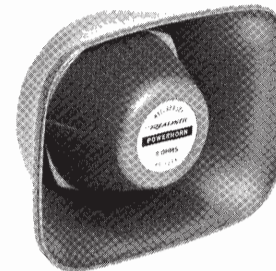

40-1244



279-200

TYPES OF SIGNALS YOU'LL BE ABLE TO MONITOR

Your community is alive with action—action which is constantly being reported on the air waves. And your PRO-45 will automatically scan the air waves to bring you that action—your police force at work, a fire truck on a mission, Sheriff's department, State police, the National Weather Service, Ham Radio operators, highway and other emergency-type services, some industrial services, some transportation services (taxi, trucks, railroad), plus some Government services. Lots of things are going on that most of us just are never aware of. But, with the right frequency crystals in your PRO-45, you can monitor such exciting signals. You'll have to do a little investigation in your community to find out what services are active and on what frequencies. You will find one of our books to be very interesting and helpful in this area: *REALISTIC GUIDE TO POLICE, FIRE AND AIRCRAFT RADIO*.

What to listen for and where? That is a little difficult for a specific answer. Each area of the country can and will use different channels. All we can do is give you some general pointers and then let you take it from there.

Find out if there is a local club which monitors these frequencies. Often a local electronics repair shop that does work on the equipment can give you the channel frequencies used by local radio services. A volunteer police or fire employee can also be a good source of this information.

An interesting service is the Mobile Telephone. FCC has assigned this service channels in the range of 152.51 to 152.81 MHz at every 0.030 MHz (channels are 30 kHz apart).

As a general rule on VHF-Hi, most activity will be concentrated between 153.785 and 155.98 and then again from 158.73 to 159.46 MHz. Here you'll find local government, police, fire and most such emergency services. If you are near a railroad yard or major railroad tracks, look around 160.0 to 161.9 for them. A most helpful book is

Radio Shack's Radio Directory. Nine volumes are published; each covers a different geographical area of the USA. These books give complete listings of frequencies used by various popular service. You'll find these books to be absolute "musts" for monitor receiver use.

NATIONAL WEATHER SERVICE RECEPTION

Continuous weather broadcasts are transmitted 24 hours a day in many parts of the country. If you are using a frequency of one of the three channels assigned (162.55, 162.40 or 162.475 MHz), your PRO-45 will automatically lock-in on that channel, since the broadcasts are continuous. To prevent automatic locking, set the channel lock-out button for that channel to the "off" position (button out). When you want a weather report, set the Channel Switch to the "on" position (press in) for that channel. In areas where stations are close to each other, one will use 162.55, another will use 162.40 and a third might use 162.475 MHz. Check with your local FCC office or the Weather Bureau for the frequency used in your area.

MAINTENANCE

The PRO-45 is a ruggedly built electronic unit, with all parts conservatively rated. However, you should treat it with care; don't subject it to excessively rough handling. You will find it will give you long life if kept free from dirt and excessive humidity.

BLOCK DIAGRAM

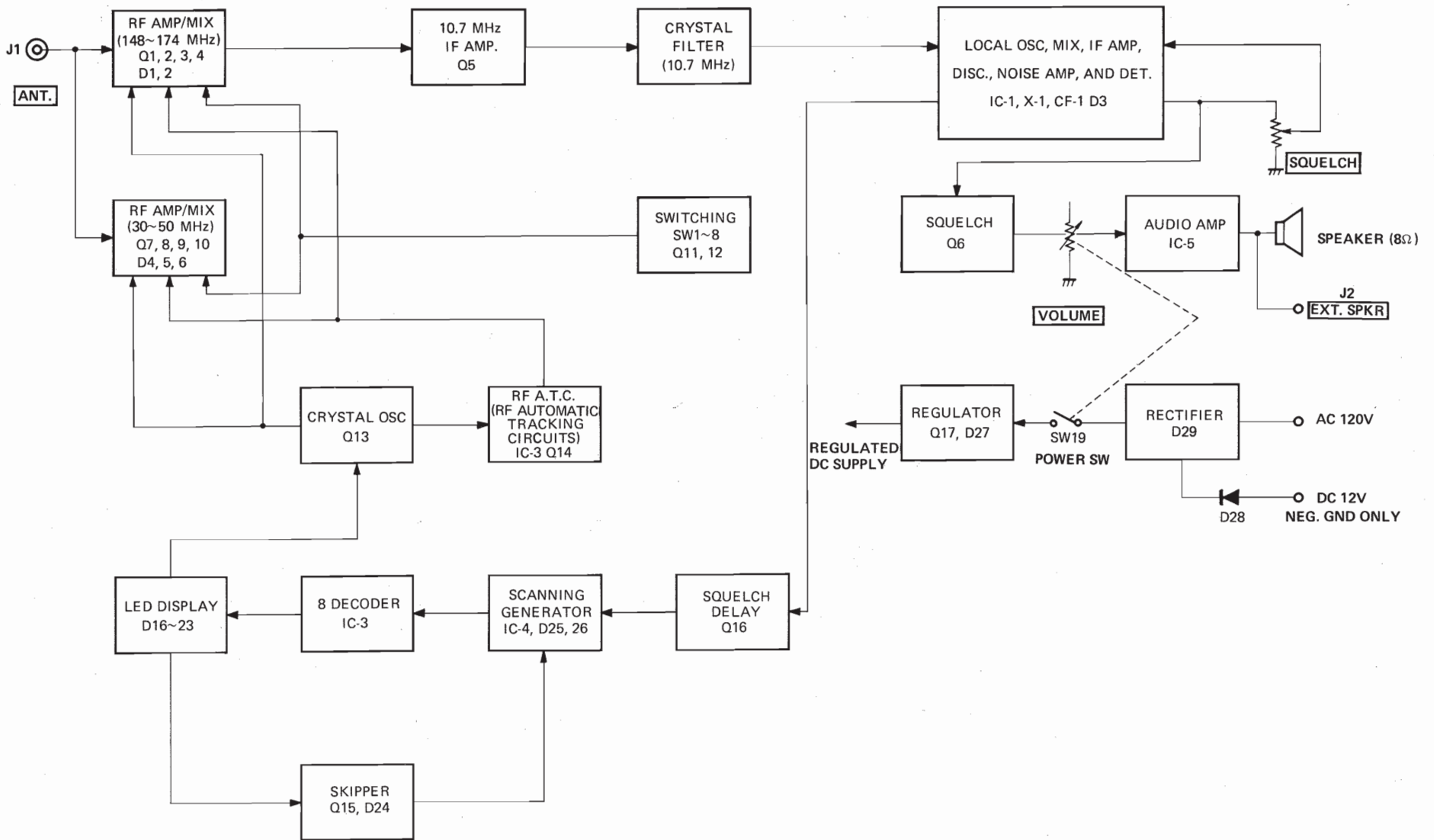

SCHEMATIC DIAGRAM

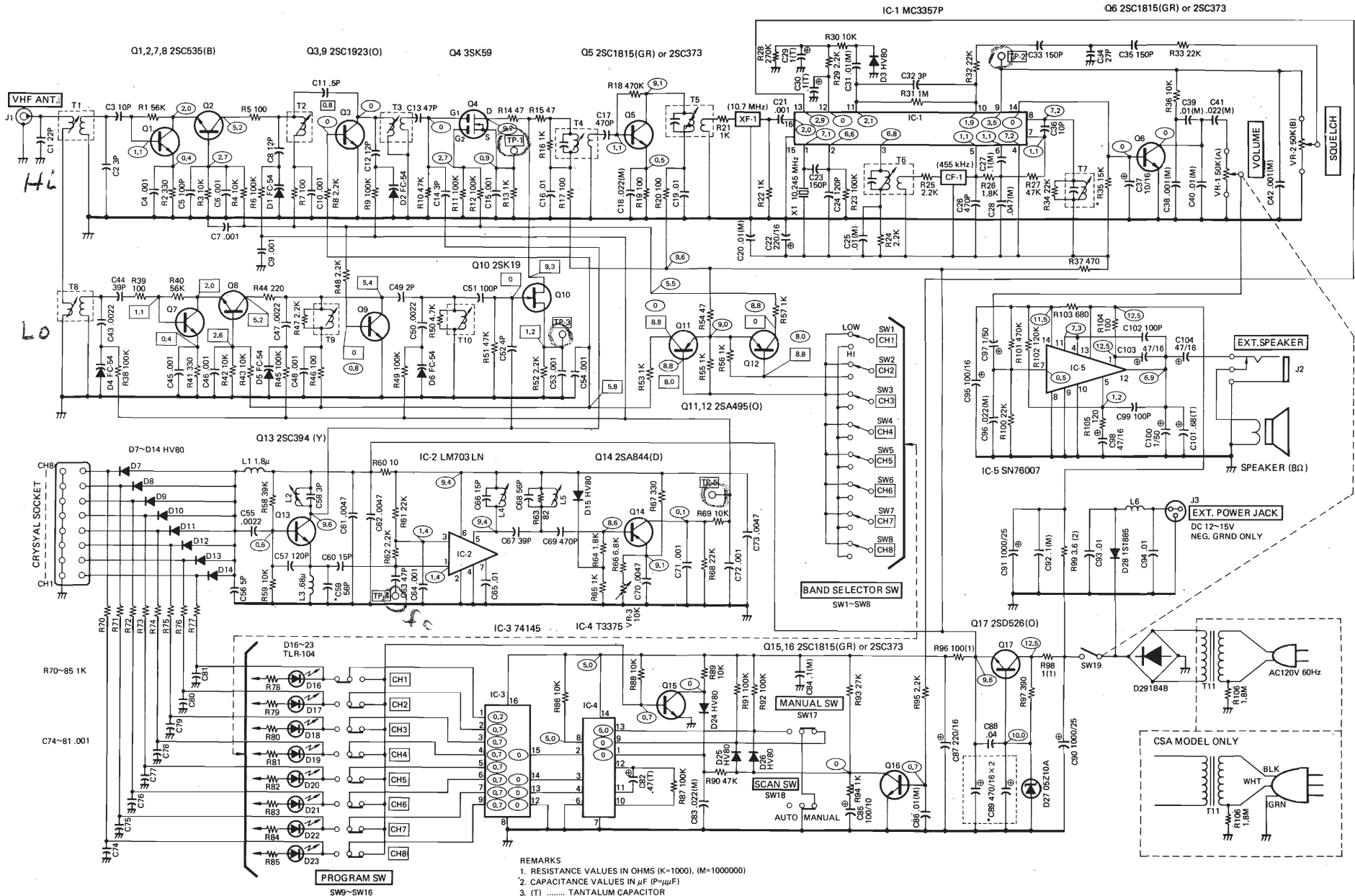

RADIO SHACK LIMITED WARRANTY

This equipment is warranted against defects for 1 year from date of purchase. Within this period, we will repair it without charge for parts and labor. Simply **bring your sales slip** as proof of purchase date to any Radio Shack store. Warranty does not cover transportation costs. Nor does it cover equipment subjected to misuse or accidental damage.

This Warranty gives you specific legal rights and you may also have other rights which vary from state to state.

We Service What We Sell

RADIO SHACK  A DIVISION OF TANDY CORPORATION

U.S.A.: FORT WORTH, TEXAS 76102
CANADA: BARRIE, ONTARIO L4M 4W5

TANDY CORPORATION

AUSTRALIA
280-316 VICTORIA ROAD
RYDALMERE, N.S.W. 2116

BELGIUM
PARC INDUSTRIEL DE NANINNE
5140 NANINNE

U. K.
BILSTON ROAD
WEDNESBURY, WEST MIDLANDS WS10 7JN